

INSTRUCTION MANUAL

Model 7800 Visual Imaging and Patching Chamber For Upright and Inverted Microscopes



Campden Instruments Limited
PO Box 8148
Loughborough
LE12 7XT
UK

Tel: (+44) 01509 814790
Fax: (+44) 01509 817701
Email: uksales@campdeninstruments.com

Campden Instruments USA
At Lafayette Instrument Co.
3700 Sagamore Parkway North
Lafayette
Indiana 47903
USA

Tel: (+1) 765 423 1505
Fax: (+1) 765 423 4111
Email: ussales@campdeninstruments.com

EC DECLARATION OF CONFORMITY



Name and address of Manufacturer:

**CAMPDEN INSTRUMENTS LIMITED
PO BOX 8148
LOUGHBOROUGH
LE12 7XT
ENGLAND**

Description of Machine:

Visual Imaging and Patching Chamber

Model number: **7800**

Serial Number:

The machine specified above complies with the relevant health and safety requirements of the following:

1. EC Directive(s):

Electromagnetic Compatibility Directive 89/336/EEC
The Low Voltage Directive 73/23/EEC

2. UK Regulations:

Electricity at Work Regulations 1989

3. European Standards

EN 50081-1: 1992 Electromagnetic compatibility generic emissions standard part 1
EN 50082-1: 1992 Electromagnetic compatibility generic immunity standard part 1

Additionally, the health and safety requirements of the following British and harmonised European Standards have been incorporated in the design of the above machine:

BS 2771:part 1:1986 (EN 60 204: Part1: 1985)
BS 5304:1988

© Campden Instruments Limited 2007

All rights reserved. The information contained in this manual is the property and copyright of Campden Instruments Limited. No part of this manual may be reproduced in any form or by any means (including photocopying or storing in any medium by electronic means) without the written permission of the copyright holder.

The purpose of this manual is to allow the user to achieve expertise in the use of the Instrument and to give the maintenance technician an insight into maintaining the instrument in peak operating condition.

Please read and understand the information contained in this manual before using the instrument. Only competent and capable personnel should use the instrument.

This document should be retained for future reference as it contains the name and address of the manufacturer within the EC

PACKAGING

Please retain the original packaging for future use.

Instruments will not be accepted for service or repair unless the unit has been adequately and properly packaged. Additionally instruments will not be accepted without prior authorisation and have been certified as being uncontaminated with any material that may be hazardous to the health of service personnel. Returns Authorisation and Decontamination Certificate forms can be obtained by contacting Campden Instruments.

1. Introduction

The 7800 Visual Patching and Imaging Chamber consists of an aluminium heat exchanger plate heated by a thin heating element. The heat exchanger supplies concentric heat to the chamber itself and in-line heat to the incoming perfusate ensuring both are heated uniformly. A thermistor embedded in the plate gives temperature feedback to the control system. In its upper surface the plate has a series of annular grooves to carry up to four perfusate tubes. The perfusate tubes carry perfusate to the central chamber at very low level encouraging laminar flow across the chamber.

A gas inlet port allows gas to be introduced for hypoxia studies. Gas flows around the grooves and is heated, eventually exhausting into the central chamber through radial grooves. The heat exchanger plate is coated on all surfaces with p.t.f.e. to discourage drug adhesion. Considerable attention in the design stage has resulted in a chamber with a very low profile reducing the likelihood of the unit interfering with the objective lens and instrumentation probes, electrodes, etc. Because the unit is very compact, the heater output has been closely balanced to the thermal mass of the heat exchanger and the likely demands of perfusate/gas flow. The unit should therefore be protected as much as possible from outside influences such as cold draughts, open doors and windows that may cause unexpected and unwanted variations in temperature.

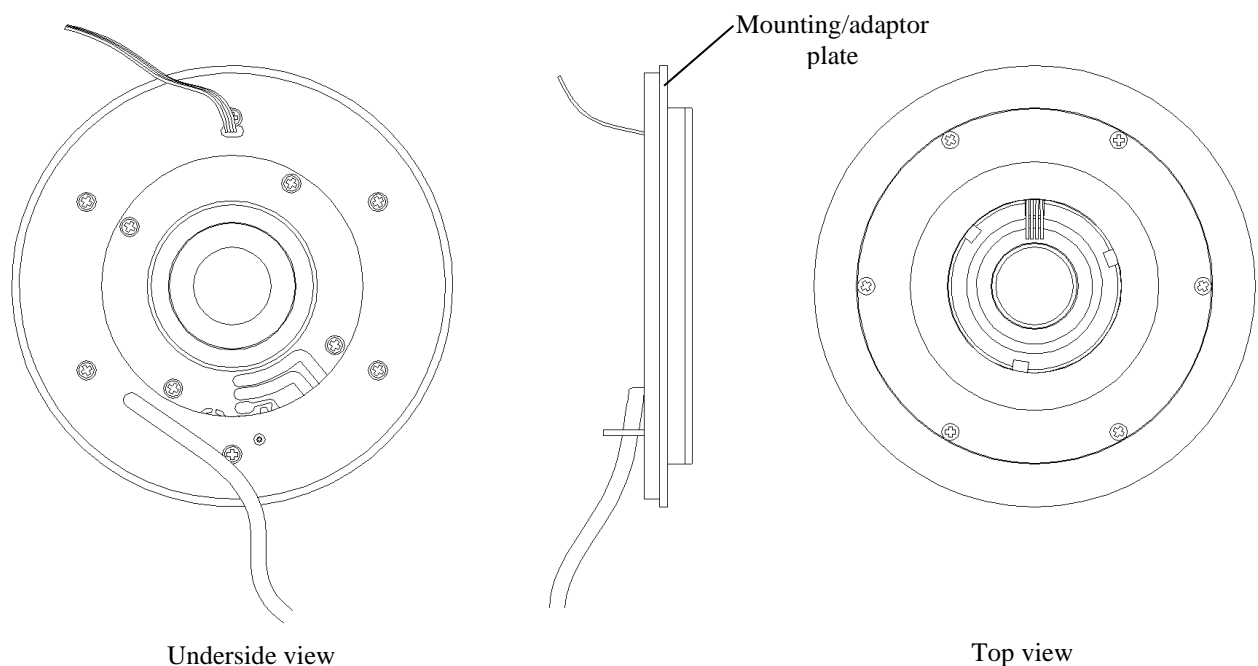

Figure 1: General Features of the Visual Patching and Imaging Chamber

The temperature controller using PID (Proportional Integral Derivative) algorithms allows close control of the perfusate temperature to within ± 0.1 Celsius. A second temperature feedback probe can be placed in the central chamber and connected to the controller allowing both chamber temperature and temperature offset (between perfusate and chamber) to be established.

The controller also provides power to the microscope objective lens heater.

The controller has analogue data output capabilities. All power outputs from the controller are DC ensuring that there are no electromagnetic noise emissions to interfere with other instrumentation.

A unique design of suction capillary tube ensures a steady flow of waste perfusate from the centre chamber whilst maintaining a smooth, constant level of perfusate in the centre chamber. The suction tube is adjustable for perfusate depth and has a low profile to avoid interference with other instrumentation probes.

The heat exchanger plate is designed to accept a 22mm slip carrier (along with a vented, double glazed cover if required for hypoxia studies) or a 35mm Petri type dish. Additional slip carriers and chambers to special designs

are available on request.

The heat exchanger is mounted on the microscope stage via an insulating adapter ring. The adapter ring may be specified with a location diameter of 108mm or 110mm, making the unit suitable for the majority of upright and inverted microscopes. Other adapter rings to suit a particular microscope can be supplied on request.

2. Set-up

Perfusate tubing.

The chamber is able to accommodate various sizes of tubing for the supply of perfusate. The chamber is supplied pre-fitted with four lengths of p.t.f.e. tubing – 2 lengths with 0.3mm nominal bore and 2 lengths with 0.5mm nominal bore.

The chamber has two grooves for tubing and can accommodate tubing in the following combinations (per groove):

2 lengths of 0.3mm bore x 0.75 outside diameter

Or

1 length of 0.3mm bore x 0.75 outside diameter
and 1 length of 0.5mm bore x 1mm outside diameter

Or

1 length of 0.5mm bore x 1mm outside diameter

Or

1 length of 0.75mm bore x 1.4mm outside diameter

Part numbers for the different tubes are listed at the end of this manual.

The tubing may be removed or replaced by carrying out the following procedure.
 It may be easier to replace the tubing by removing the chamber assembly from the microscope stage.

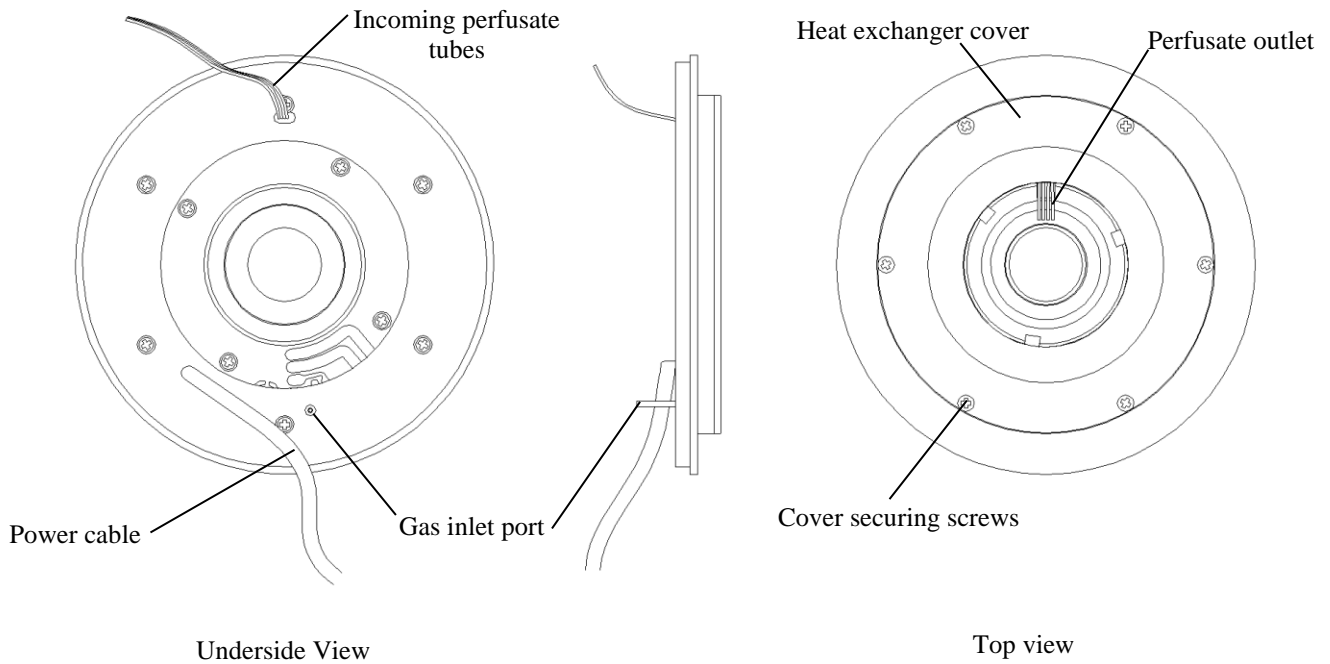

Figure 2

Refer to figures 2 & 3

Remove 6 countersunk screws securing the heat exchanger cover.

Note the manner in which the existing tubing has been routed through the heat exchanger grooves. Remove the tubing.

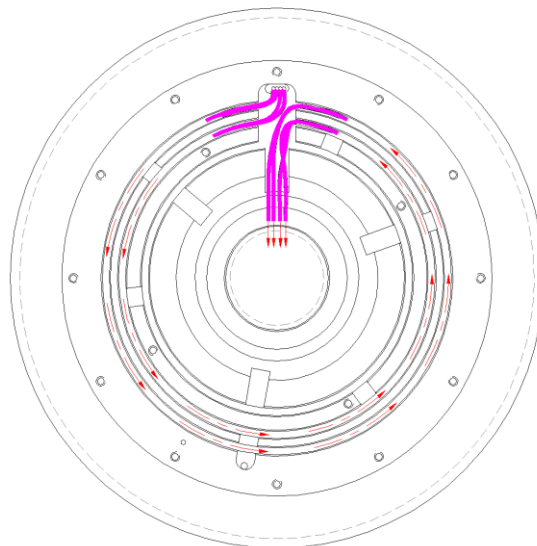

Figure 3: Routing of Perfusate Tubing

Thread the replacement tubes through the inlet port. Each groove can accommodate lengths of tubing as described above. Lay the tubing into the grooves. Do not attempt to fit more tubes per groove than recommended otherwise the tubing will be squashed, inhibiting perfusate flow.

Useful tip: The tubing may be secured in place with a number of small pieces of self adhesive tape (e.g. Sellotape®) bridging the groove. Although the heat exchanger is coated with p.t.f.e. there will be sufficient grip for the tape to temporarily hold the tubing in place.

Continue to lay and secure the tubing in its groove until a full 360° length of tubing has been positioned. Carefully bend the tubing so that it can exit the heat exchanger through the widest of the four radial channels in the centre of the exchanger.

Ensure that the tubing is lying completely within its groove at both the entrance and exit of the groove.

Useful tip: Take extra care where the tubes enter and exit the grooves – it is easy to trap and squash the tubing in these areas when the cover is replaced.

If it is intended to pass gas through the heat exchanger as well as tubing, place a thin smear of silicone grease around the heat exchanger outer rim surface to form a gas tight seal when the cover is replaced. Do not allow grease to enter the grooves or gas flow may be impeded.

Refit the exchanger cover.

Useful tip: It may be easier to place the cover on the exchanger and loosely fit just one screw as shown in figure 4. The cover can then be swivelled across the exchanger whilst ensuring that the tubing remains properly in place before fitting the remaining screws.

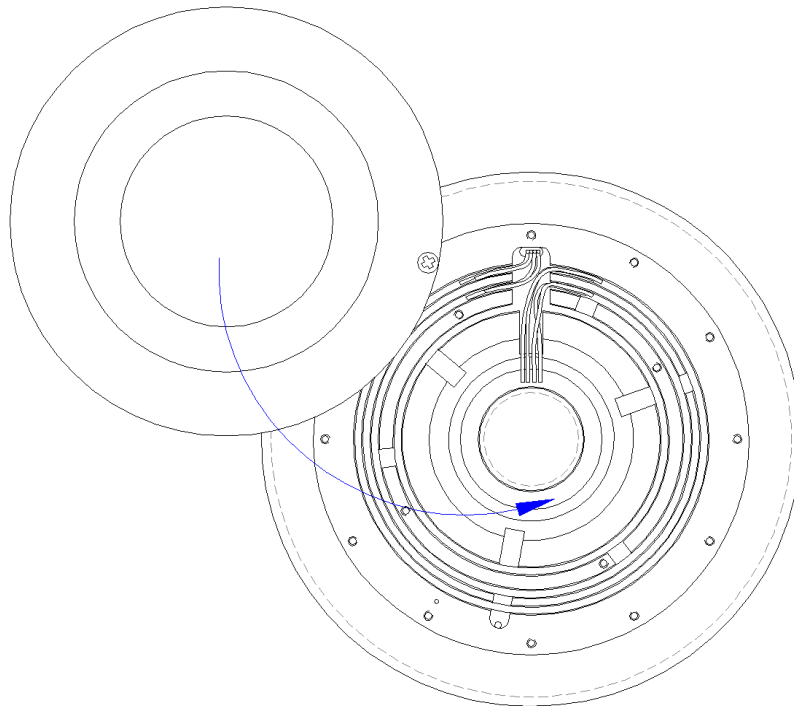

Figure 4: Refitting the Cover

With the cover satisfactorily in place, trim the tubing to the desired length.

Useful tip: Use a soldering iron with a fine tip to put a permanent bend in the tubing as it exits from under the cover so that the ends of the tubing are pointing down into the central area. Take care not to overheat the tubing such that it melts. The tubing may then be trimmed carefully to the correct length. See figures 5a and 5b.

Useful tip: If the permanent bend is positioned slightly away from the heat exchanger so that the outlet of the perfusate tubes are not resting on the heat exchanger then 'wicking' or back capillary action of perfusate will be avoided. A 'hairpin bend' in the tube (figure 5c) also has the same effect. See also figure 6.

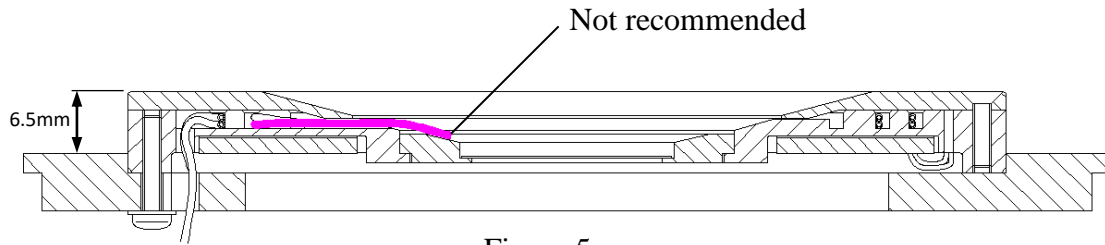

Figure 5a

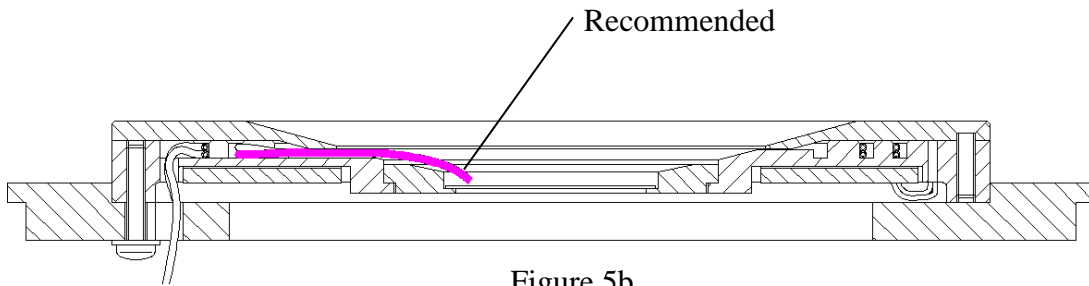

Figure 5b

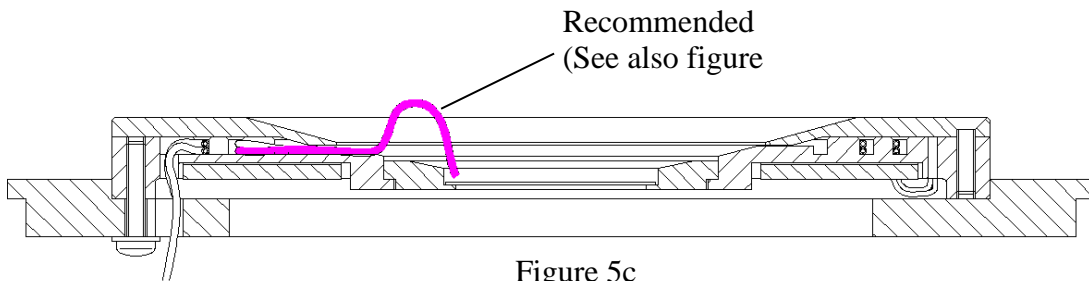

Figure 5c

Figure 5

Figure 6, below, shows a convenient method of obtaining the non-wicking profile shown in figure 5c. This is achieved by threading the tubes through the swan neck former 7800-7.

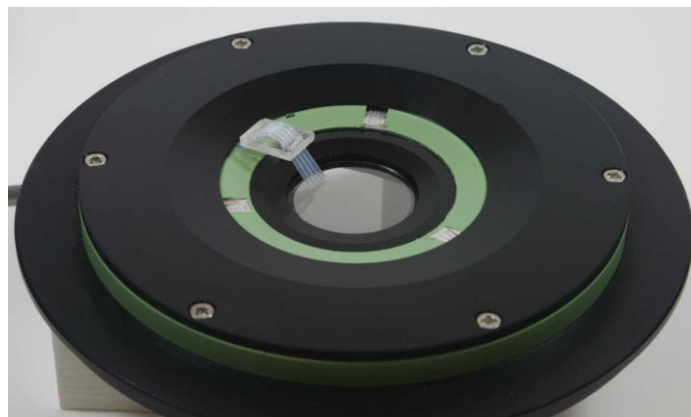

Figure 6

Normal rate of perfusion allowing efficient heat transfer to the perfusate is 1-2 ml/min.

Tubing should be washed with distilled water after every use by simply placing the inlet into a distilled water bottle and pumping through. Additionally the tubing should be flushed periodically for 1 hour with 50% citric acid.

Gas supply

The heat exchanger also has the facility to heat an incoming gas supply for hypoxia studies. In this instance the gas supply must be connected to the gas inlet port – see figure 2. Gas then flows into the heat exchanger, around the grooves and exits via three gas slots into the central area.

The gas inlet port consists of a short length of stainless steel hypo tubing pressed into the body of the exchanger. The hypo tubing should not be removed or replaced on a frequent basis otherwise the security of fit will be affected leading to gas leakage and possible corrosion of the heat exchanger. The gas supply tube should be pushed over the open end of the protruding hypo tube.

Central chamber

Slip carrier (Part number 7800-3)

Thoroughly clean the slip carrier and cover slip (22mm).

Refer to figure 7

Apply a thin film of silicon adhesive to the inner lip of the carrier and gently press the cover slip onto it ensuring that the adhesive forms a continuous bond between the carrier and slip.

See further notes below ‘Silicone Adhesives’ for more information on suitable adhesives.

Allow the adhesive to cure.

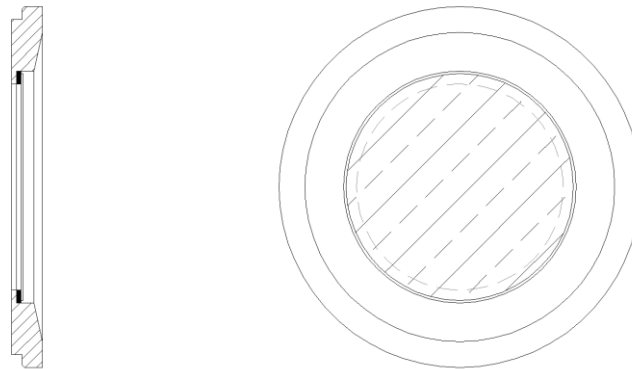

Figure 7: Central Chamber and 22mm Slip

The slip carrier has a close push fit with the heat exchanger, care should be taken not to damage the slip when inserting (or removing) the carrier into the heat exchanger.

Double glazed cover (Part number 7800-6)

Fit a 22mm cover slip to each side of the cover carrier using the same procedure described above for the central chamber. See figure 8

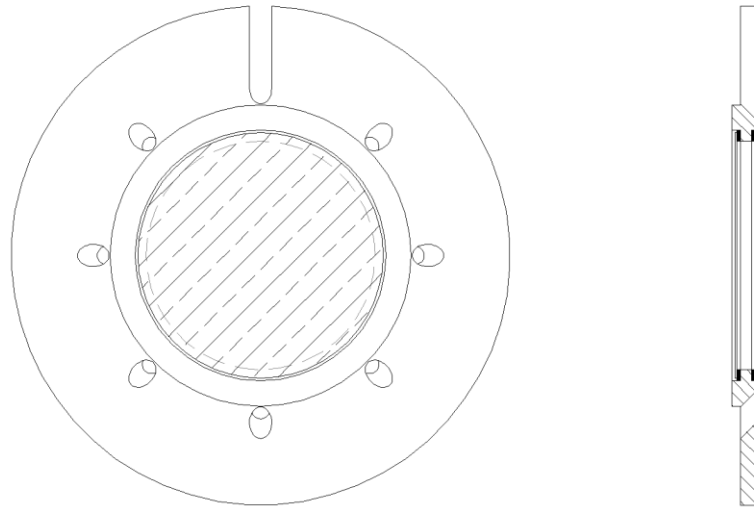

Figure 8: Double Glazed Chamber Cover

The cover is fitted to the heat exchanger by simply resting it on the exchanger body and locates in the inner diameter of the upper cover. A smear of silicone grease may be applied if desired to enhance gas sealing. A series of vent holes in the double glazed cover allow excess gas to vent and the insertion of probes.

Alternatives to the standard slip carrier

1. Petri dish

A 35mm Petri type dish may be used instead of the 22mm standard slip carrier. The unit has been designed to accept a Nuncbrand 35 x 10 Nunclon dish, catalogue number 153066. The use of this dish is illustrated below in figure 9.

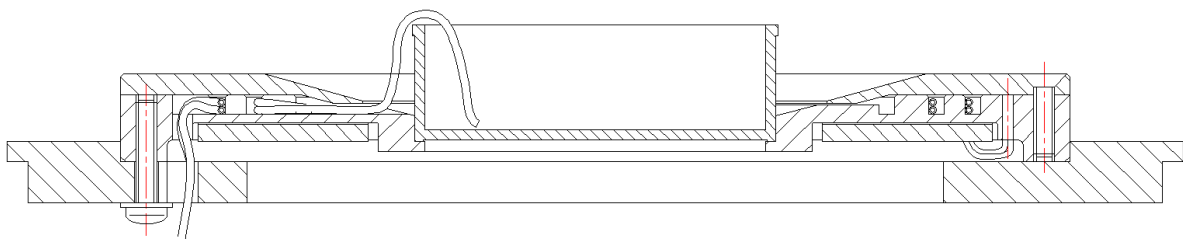

Figure 9: Using a Nunclon 35mm Petri type dish

2. Holder for removable slip (Part number 7800-4)

A second holder, also suitable for a 22 mm slip, is available. This version is made in two pieces (see figure 10) allowing the slip to be lightly trapped between the two components. The slip should be sealed using suitable silicon grease. See further notes below 'Silicone Adhesives' for more information on suitable adhesives/greases. The double glazed cover may still be used with this holder if required.

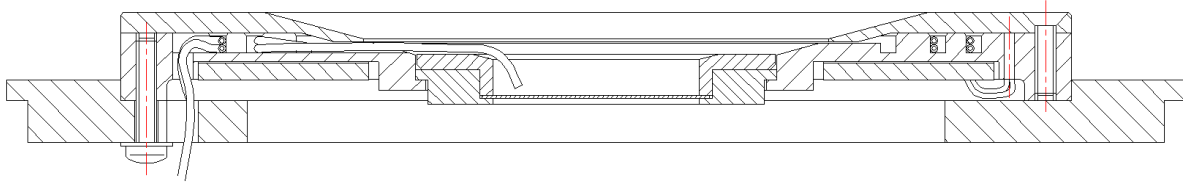

Figure 10: Holder for removable slip.

Silicone Adhesives

A number of different silicone based adhesives suitable for fixing cover slips are available. Dow Corning manufactures an adhesive that is certified as being non-cytotoxic (post cure) – Silastic Medical Adhesive Silicone Type A – you should consult your local Dow Corning office for further information and availability regarding this product.

A number of researchers have used other Dow Corning products with success, these are described below. We make no other statement or warranty regarding the suitability of these products and you should satisfy yourself regarding their suitability before using them.

Dow Corning 732 Multi-purpose Sealant – a non-sag room temperature curing adhesive

Dow Corning 734 Flowable Sealant – a low viscosity, solvent free sealant/adhesive

Dow Corning 4 Electrical Insulating Compound – a grease like material

All the above materials have sufficiently low adhesive characteristics allowing easy removal of cover slips from the slip carriers in the event that replacement is required.

Perfusate extraction

For optimum use the end of the suction needle must be prepared as shown in figure 11.

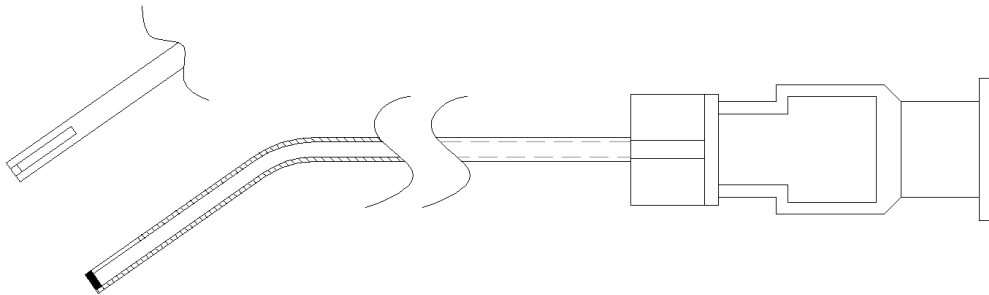

Figure 11: Preparation of the Suction Needle

The open end of the needle must be closed with a very small plug of silicon sealant. The slot in the end however must remain open.

The perfusate extraction suction needle is a push fit into the adjustable mount. The adjustable mount can be fixed to the microscope stage by methods such as double sided tape or two pieces of self-adhesive magnetic strip as shown in figure 11. Magnetic strip does have the advantage of allowing easy removal and replacement of the needle and adjustable mount.

It is recommended that the tip of the needle should be immersed in the perfusate but the majority of the open slot is not immersed. The outlet of the needle has a Luer taper for easy connection to tubing.

It should be noted that for the extraction needle to be properly effective, the inside surface of the needle should be thoroughly wetted. Steel is naturally hydrophobic and complete wetting can be difficult. The needles supplied by Campden are wetted and supplied in water filled containers. After use, the needles should be kept stored in the same (or a similar) container filled with water.

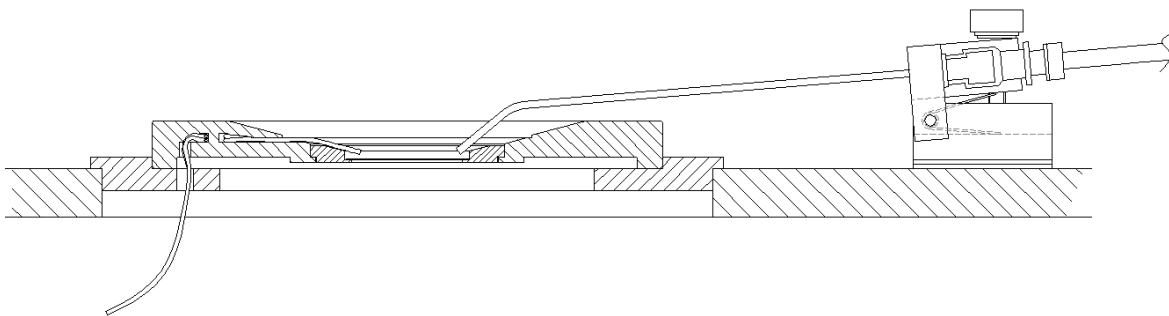

Figure 12: Positioning the Suction Needle

Assuming that the perfusate is fed and extracted by a peristaltic pump, the pump tubing should be chosen such that the perfusate extraction rate is of the order of 8-10x the inlet flow rate. Trials have shown that the resulting combination of perfusate and gas (air) extracted through the needle leads to a very stable perfusate level in the chamber. The exact depth of immersion for any given experiment can only be judged by trial and error owing to the large number of variables involved.

3. Operation of the Temperature Controller

Before connecting the unit to a mains supply, the unit must be set for your particular voltage supply. The voltage is set by prising out the fuse holder drawer and re-inserting it such that the voltage legend for your supply is aligned with the mark on the inlet moulding. See Figure13.

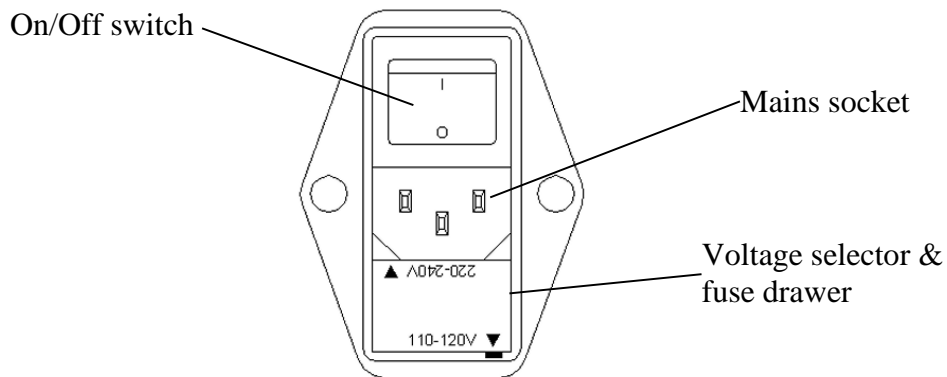

Figure13: Mains inlet/voltage selector (example shown is set to 110-120V)

The inlet moulding accepts a standard IEC socket. Where possible a standard mains lead - IEC socket/mains plug – suitable for your mains outlet will have been supplied with the instrument. The instrument must not be operated unless it is connected to a suitably earthed (grounded) mains supply.

3-1. Connections

Connect the heater controller as shown in figure 14.

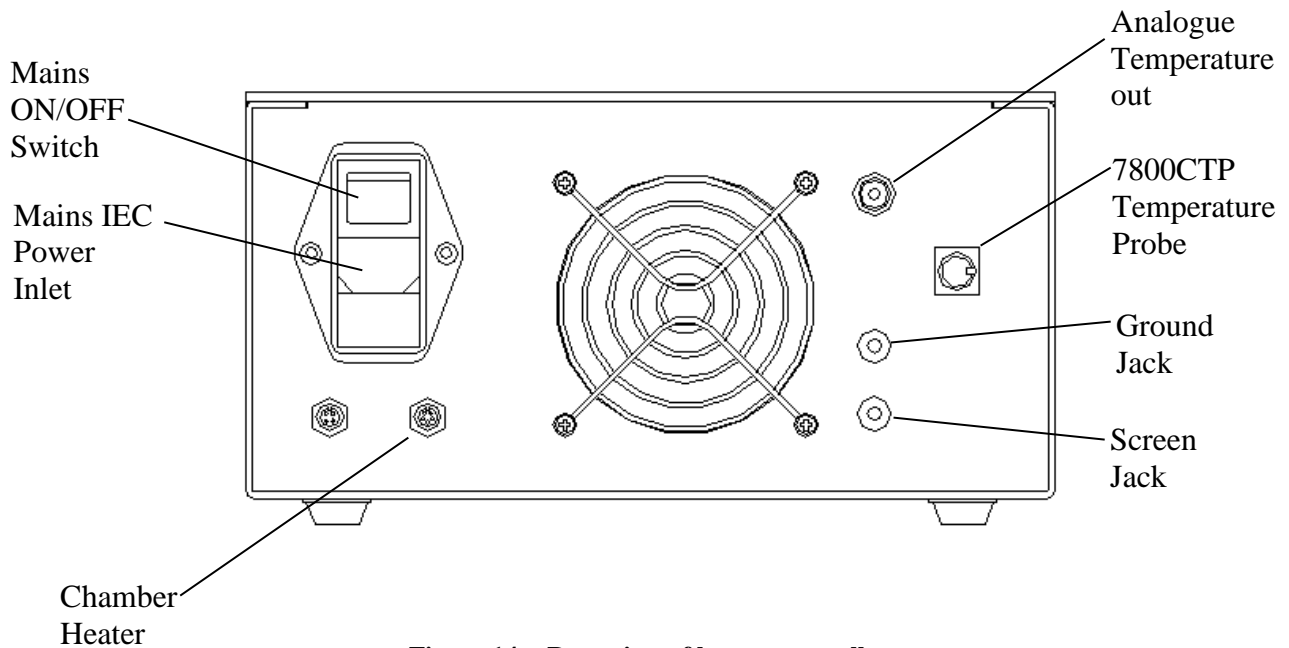

Figure 14: Rear view of heater controller

The Ground Jack (green) outlet is available to provide an electrical earthing point. It is connected internally to the earth terminal of the mains power lead. The Screen Jack (blue) outlet is connected internally to the screens

of the chamber heater and probe cables. This may be connected to a Faraday cage to provide an earth path (from the chamber/heat exchanger) to minimise electrical noise. Both connections accept 4mm jack plugs (not supplied). The BNC connection provides an analogue output of the chamber temperature. The output is scaled so that 0.00V = 0°C and 5.00V = 50°C.

3-2. Operation

Power-up

Connect the heater controller to the slice chamber as outlined above. Switch the controller on at the main switch on the rear of the unit.

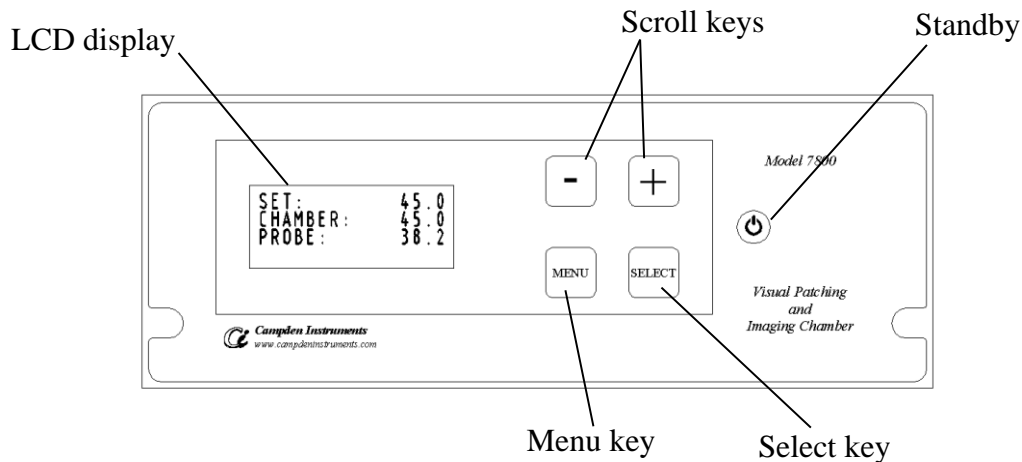

Figure 15: Controller front panel (as used with a slice chamber)

Press the standby key and the LCD display will be illuminated as shown in figure 15. The actual parameters displayed will depend upon how the unit was last used.

As shown in figure 14, the unit temperature has been 'SET' to a desired chamber temperature of 45.0 degrees. The current 'CHAMBER' temperature is also 45.0 degrees. The temperature of the chamber 'PROBE' the 7800CTP is 38.2 degrees.

If the unit has not been connected to either the slice chamber or the chamber probe, the display will show 'ERROR' against the offending connection line.

The SET figure indicates the desired temperature of the chamber heat exchanger. To change the value press either the + or - key. Each momentary press will increment (or decrement) the number to the right of the decimal point by one count. A sustained press (press and hold) will cause the number to the right of the decimal point to count through 10 points and then the numbers to the left of the decimal point to count continuously until either the key is released or the limits of the available settings have been reached.

To set a particular value, press and hold the appropriate +/- key until the approximate value has been reached and then fine tune the value by repeated momentary presses of the appropriate key. The controller will then provide power to warm the heat exchanger to the SET temperature. The limits of the temperature settings are between 30 and 55° Celsius. The unit may also be set to operate in degrees Fahrenheit, this will be explained later.

The second line 'CHAMBER' indicates the current temperature of the heat exchanger. An alarm may be set to warn if the water temperature, once it has reached the set value, subsequently drifts away (+ or -) from that set value by a preset amount. The alarm condition is indicated by a buzzer and by flashing the temperature value on and off. The display will also show 'Press Select'. Pressing the select key will reset the alarm. Note that the temperature feedback loop is provided by a thermistor embedded in the heat exchanger, not by the 7800CTP chamber temperature probe.

The third line shows the current temperature experienced by the 7800CTP chamber probe. An alarm may be set to warn if the probe temperature, once it has reached the desired value, subsequently drifts away from that

desired value. The desired value is set by pre-setting a lower and upper temperature condition. The alarm condition is indicated by a buzzer and by flashing the temperature value on and off. The display will also show 'Press Select'. Pressing the select key will reset the alarm.

3-3. Configuring the controller

As mentioned briefly in earlier sections, the controller may be configured to operate in different modes and use either degrees Celsius or Fahrenheit, may have alarms set to indicate temperature drift, etc. The controller can be configured by changing the various options available via menus and sub-menus.

To access the Menu screen, apply power to the controller and press the stand by key. Press the MENU key and the screen will change to that shown in figure 16.

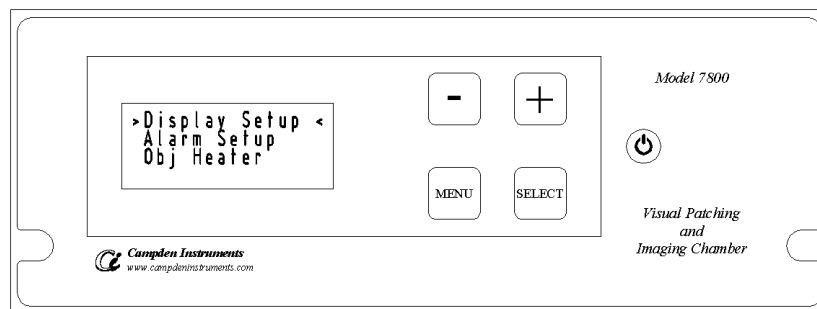

Figure 16: Controller front panel – Menu screen

The sub-menus can then be accessed using the + and – keys to scroll the > < cursors up and down the display and pressing the SELECT key. 3 sub-menus are available. The following sections outline the options within each sub-menu.

3-3-1. Display Setup

The unit can display the chamber temperature and probe temperature with a resolution of 1 or 2 decimal points and can be set to operate in either degrees Celsius or Fahrenheit.

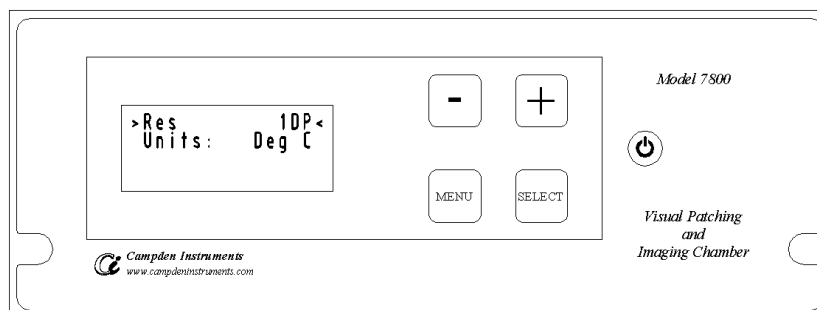

Figure 17: Controller front panel – Display Setup

Temperature resolution.

The resolution of both the chamber temperature and the probe temperature may be set to either 1 or 2 decimal places. Changing the resolution will not affect its accuracy.

Press MENU and using the – and + keys move the cursors (>.... <) to the line 'Display Setup'.

Press SELECT and the lines RES and Units are shown.

Move the cursors to the RES line and press SELECT. The cursors will change from > < to = =. The resolution of the chamber probe may now be toggled between 1 decimal place and 2 decimal places using either the + or – keys. When the resolution has been set as desired, press either the MENU or SELECT keys.

Pressing the MENU key will change the display back to the main menu screen. Press MENU again to get back to the normal operating display and mode.

Pressing the SELECT key will change the display back to the Display Setup screen.

Temperature scale.

Move the cursors to the Units line and press SELECT. The cursors will change from > < to = =. The temperature scale may now be toggled between Celsius (shown by ‘Deg C’) and Fahrenheit (shown by ‘Deg F’). When the appropriate selection has been made press either the MENU or SELECT keys.

Pressing the SELECT key will change the display back to the Display Setup screen.

Pressing the MENU key will change the display back to the main menu. Press MENU again to get back to the normal operating display and mode.

3-3-2. Alarm Setup.

The unit has two alarms available to provide indication of abnormal operation.

As the water bath is heated the controller monitors the situation by a PID algorithm. When the temperature in the water bath reaches the set temperature the controller attempts to maintain the water at that temperature. An alarm within the controller may be set so that if an event causes the water in the bath to drift away from that temperature by a predetermined amount an alarm will operate. The chamber probe may also have an alarm condition. This is defined by entering the upper and lower temperature limits of the probe alarm envelope. If the alarm has been set and is subsequently triggered, a buzzer will sound and the appropriate display line (water or probe) will flash on and off. The display will also show ‘Press Select’. Pressing the select key will reset the alarm.

To access the alarm menu press the MENU key to get to the menu screen. Using the + and – keys scroll the > < cursors to the line Alarm Setup and press the SELECT key.

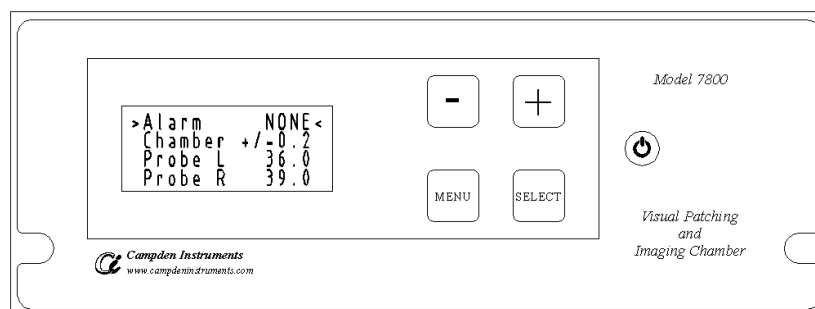

Figure 18: Controller front panel – Alarm screen

The display will change to show the Alarm screen shown in figure 18.

The first line shows which of the alarms have been enabled. The selection may be toggled between NONE, PROBE, CHAMB and BOTH. Press SELECT and use the + and – keys to select the desired output. Press SELECT again to get back to the Alarm set up screen.

The second line shows the tolerance value about the set point of the chamber heat exchanger alarm. To change the alarm value scroll the cursors to the appropriate line and press SELECT. The + /- tolerance can now be adjusted between +/- 0.1 and +/- 2.0° Celsius (or +/-0.2 and +/-3.6° Fahrenheit).

The third and fourth lines show the upper and lower envelope conditions of the probe alarm. To change the alarm value scroll the cursors to the appropriate line and press SELECT. The alarm value can now be changed. Note the lower limit will not be allowed within 0.2° C or above of the upper limit and visa versa.

When the appropriate selections have been made press either the MENU or SELECT keys.

Pressing the SELECT key will change the display back to the Alarm Setup screen.

Pressing the MENU key will change the display back to the main menu. Press MENU again to get back to the normal operating display and mode.

3-4. Practical considerations when operating the heater controller.

Once the unit is switched on the chamber heat exchanger will be heated to the set temperature. It should take approximately 15 minutes for a unit to reach the set temperature. Outside influences such as ambient temperature will affect this time.

Once the temperature in the chamber has stabilised, the 7800CTP temperature probe should be used to ascertain the temperature offset between the heat exchange and the specimen chamber. Using this temperature difference the chamber 'SET' temperature can be readjusted so that the specimen chamber reaches the desired temperature. The 7800CTP probe is very sensitive and will react to extraneous influences such as draughts, opening doors, etc very quickly. If the probe is poorly positioned it may give unexpected and misleading indications.

4. Cleaning & Maintenance

The 7800 Control unit contains no user-serviceable parts and requires no maintenance.

The 7800 Chamber requires only cleaning after use. Since the chamber contains electrical circuits and electronic components it must not be sterilised by autoclaving methods nor must it be immersed in water. The unit can be cleaned by removing the central chamber, upper cover and tubing and then cleaning all parts with detergent based fluids. Solvents should not be used.

Tubing should be washed with distilled water after every use by simply placing the inlet into a distilled water bottle and pumping through.

Additionally the tubing should be flushed periodically for 1 hour with 50% citric acid.

All electrical instruments and equipment should be periodically tested to ensure they remain safe to use. In some countries this may be a statutory requirement. Your local Health and Safety Executive (or equivalent) will be able to advise on this matter.

Order codes

Description	Order code
Visual Patching and Imaging chamber (complete)	7800
Replacement parts:	
Control Unit	7800-1
Visual Patching and Imaging Chamber	7800-2
Inner chamber, shallow profile for electrode access	7800-3
Inner chamber with removable coverslip	7800-4
Replacement perfusate tubing 0.3mm bore (pack of 4 @ 1m long)	7800-5-0.3
Replacement perfusate tubing 0.5mm bore (pack of 4 @ 1m long)	7800-5-0.5
Replacement perfusate tubing 0.8mm bore (pack of 4 @ 1m long)	7800-5-0.8
Standard double glazed cover	7800-6
Swan neck former	7800-7
Replacement hand held temperature probe	7800-8
Replacement suction needle	7800-14
Replacement suction needle (pack of 3)	7800-14-3
Replacement suction needle base (adjustable) (c/w 1 needle)	7800-9

Specification

Display Resolution	0.1°C or 0.01°C
Temperature Accuracy	+/- 0.1 °C
Heater Temperature Range	+30°C to 55°C
(Note that the actual temperatures achievable will be dependent upon the perfusate flow rates and local temperature conditions)	
Voltage requirements	230V 50Hz or 115V 60Hz
Power Rating	60W
Inlet Fuse Rating	T1.25A
Overall Diameter of 7800 Chamber	114mm
Overall Height of 7800 Chamber	12.5mm
Height to top of 7800 Chamber when mounted and recessed into platform	6.5mm

For further information contact:
CAMPDEN INSTRUMENTS,
PO BOX 8148
LOUGHBOROUGH,
LEICESTERSHIRE
LE12 7XT.
UK.

Telephone: (+44) 0150 981 4790

Fax: (+44) 0150 981 7701

Mail@campdeninstruments.com

www.campdeninstruments.com